

## CHASING YOUR TAILINGS: A REVIEW OF PLACER MINING TECHNOLOGY

Susan Lindström, Consulting Archaeologist, Truckee, California  
John Wells, Consulting Mining Engineer, El Dorado Hills, California  
Norman Wilson, Mining Historian, Auburn, California

### ABSTRACT

An accurate interpretation of placer mining sites requires both an appreciation of the nature of gold deposition and an understanding of the mechanics of gold recovery. Miners were impelled to confront a variety of topographic, hydrologic and geologic conditions which required specialized technologies in gold extraction. In certain areas, shallow deposits covered the bedrock with a thin layer of rich gravels, which were easily washed by simple water-conserving methods using pans, rockers and rudimentary ground sluicing techniques. With the development of water distribution and storage systems, more efficient extractive techniques involving long toms, sluices, and hoses were possible. Away from the existing stream corridors, gold-bearing auriferous gravels of ancestral rivers were much deeper, and were more profitably worked by drifting and hydraulicking and later with bucket-line, dragline and dry-land dredging.

The suite of archaeological landscape features that are typically associated with these placer mining techniques often occur as a complex and multi-layered veneer of mounds, pits and trenches. In the absence of diagnostic artifacts, it is the mining landscape that is most useful in understanding the context and character of human activities. Yet, this topographic legacy is among the most poorly understood and appreciated of the heritage features associated with mining sites. Collectively, these durable placer mining landscape features are considered according to their: (1) morphology and distribution, as a reflection of the organization of the placer mining process; (2) evolution, as an indicator of time-specific technological processes; and (3) deterioration over time, as affirmed by relative dating techniques.

### INTRODUCTION

The placer mining landscape bears distinctive archaeological signatures that can be most useful in understanding the context, character and timing of historic mining activities. Tailings are just one component of a total technological system, comprised of a well-integrated complex of water

delivery networks, gold prospecting – recovery – milling processes, waste deposit areas, and associated transportation systems and habitation centers. This brief overview of major placer tailings types and their corresponding technologies, and methods for their recordation and interpretation, is drawn from a number of comprehensive and comparative studies that have been conducted on large mining landscapes within the Mother Lode region (Lindström 1994; Lindström *et al* 1994; Lindström and Wells 1989, 1990; Lindström, Wells and Wilson 1988a, 1988b, 1993a, 1993b, 1994).

### TECHNIQUES AND TAILINGS

The Gold Rush was an epic of technology, as a multi-ethnic polyglot of Californians re-discovered and/or re-invented the technology of mining. By the mid 1850s the "cream" was quickly skimmed from shallow stream bars and benches by the initial rush of miners using shallow hand-mining techniques with pans, rockers, long toms, and sluices. Miners were soon drawn away from the existing stream corridors to the gold-bearing auriferous gravels of ancestral rivers, which were much deeper and were more profitably worked by drifting and hydraulicking and later by dredging.

The real value of claims was found when mining companies, stoked with capital, bought out the single "pick-and-shovel" miners and brought in big equipment to work the claims.

Each successive stage of technological development urged more complex socio-economic formations and effected more radical rearrangements of the landscape. It took a solitary individual to pan for gold. A few men assembled, at most, to efficiently work a rocker or long tom. It took at least half a dozen to build and operate a sluice. It could take hundreds more to wash away entire mountains through hydraulic assault. Correspondingly, residual landscapes from the ferocious hydraulic monitors left 100-foot high sheer cliffs. In contrast, simple placering methods created a subtle topography with pits and mounds barely in relief.

#### Water Management

Placer mining involves the use of water in the removal of "free" gold that has been fortuitously caught in the gravels of modern and ancient streambeds. In order to work "dry diggings" away from the existing water courses, it is necessary to bring large volumes of water to the claims by ditch, flume and/or canvas hose. Gradually, water supply needs necessitate the formation of large mining and water supply companies to develop and manage the elaborate supply network necessary to make mining cost effective. Miners pay for rights to water delivered to them.

Ditches are constructed on relatively flat ridge tops in the vicinity of mining activities. From reservoirs or rivers, a series of distribution ditches carries water to areas being worked. Diggings are supplied with water from main ditches and secondary ditches or laterals (Figure 1). Small, temporary ditches are used to bring wash water to a place on the rim of a pit, from where it cascades into the working area. In some cases, it is possible to determine which areas are worked first, since many ditch segments survive as remnants isolated when upstream portions of them are mined away.

Some historic mining ditches were converted for irrigation and domestic purposes and are still flowing today. Other ditches are infilled and barely discernible, with their water supply reservoirs

breached and abandoned. Water is also supplied to the diggings by wooden flume. Riveted iron slip-joint pipe is readily moved around the mining site to deliver water with relative ease.

#### Shallow Placering

Shallow placering involves the removal of loose surface gold-bearing deposits using pick, shovel and sluice fork or washing the thin layer of rich gravels with canvas hoses. Processing is done using simple water-conserving methods such as pans, rockers, long toms, and sluice boxes. All of these devices involve the basic principle of agitating gold-bearing gravel in water-filled containers.

Panning, usually with a metal pan, is the original method of washing hand workings; it dates from the initial gold discovery in 1848. From the standpoint of simplicity, the pan has no peer.

By 1849, the pan was rapidly replaced with more efficient higher volume devices such as the wooden rocker or "miner's cradle." It takes its name from a likeness to the nineteenth century rocking baby cradle. The labor saving effected by the rocker (as compared with the pan) is about fourfold. Deposits are washed, with larger gravels being caught on a screen or punched iron sheet and smaller material falling through to the bottom. Here, heavy gold particles are trapped in the riffles placed in the bottom of the device (Figures 2-3).

For years, the rocker remained popular with itinerant Chinese miners, many of whom worked as gleaners in abandoned placer diggings.

By 1850, the long tom began to replace the rocker. Daily capacity of the long tom is five times or more that of a rocker. The long tom consists of an inclined wooden trough, about 12 feet long, with a perforated iron plate (riddle) across its lower end, and below this is a separate riffle box. Two or more men shovel gold-bearing deposits into the tom while another stirs the material and forks out the washed rocks. After passing through perforations in the riddle, the minus-half inch fines flow across the riffle box where the gold is caught (Figures 4-5).

Around 1852 both the rocker and long tom

were being replaced by the more versatile sluice. An elaboration of the long tom, the sluice is no more than an elongated, rectangular trough fitted with transverse cleats, or riffles, on its bottom. A stream of water carries the sands and gravel over the riffles which, in turn, detain any gold or heavy minerals as they settle to the bottom. Quicksilver (mercury) is sometimes put in the riffles to help catch and retain fine-size gold particles. A sluice line is formed by interconnecting the boxes end to end in a continuous line. The longer length allows more gold bearing material to settle out. Sluice boxes are either laid on the ground or are elevated on supports as flumes to maintain the proper grade or descent. When no longer serviceable, the boards are burned and the ashes are washed for gold (Figure 6).

Remnant landscape features of these mining techniques are characterized by a hummocky ground surface which is dotted with shallow pits and low mounds. This topography, of low relief, is often marked by clean-out tailings comprising small piles of fine sediment that have been dumped from a rocker or long tom when it is cleaned out.

#### Drifting

As distinguished from surface methods for placer mining, underground mining procedures applied to placer gravels are collectively known as drift mining. Narrowly defined pay streaks, buried under deep masses of low-value gravel or capped by lava flows, are usually explored by shafts or adits (Figures 7-8). Drifts are then driven into the richer portion of the gravels. Gravels are raised with a windlass and washed on site by a rocker or are transported to the nearest water source (Figures 9-10).

More rudimentary variations on drift mining are called coyoting, where shallower gravels are penetrated by excavations just big enough in which to crawl.

#### Ground Sluicing

Ground sluicing penetrates deeper into the bench gravels than any of the shallow placering techniques. Deeper is a relative term, however, as ground sluicing enterprises range from more rudimentary efforts to those on a truly grand scale. The operation is started by cutting a trench across the area to be worked in order to provide a water

course which, when reaching bedrock, becomes the ground sluice. A ditch is brought to the top of the bank to be mined, allowing a stream of water to cascade over the working face and flow through channels at the base of the gravel bank. In this way, the gravel is excavated by free-flowing water, not under pressure. The erosive force of the water is assisted by bringing down the adjacent banks with picks and by causing the water to undercut the bank and aid in its caving. The fallen material is washed through the ground sluice, where the bottom is either paved with cobbles which serve as riffles to trap the gold or lined with a sluice box equipped with wooden riffles. Washed cobbles, too large to be readily moved by the water, are either thrown from the sluice by use of a shovel or sluice fork or are vertically stacked along the edge to form a series of stone-lined, shallow water-diversion channels and retaining walls. From time to time, the water is shut off or redirected while gold, which has accumulated on the bottom of the ground sluice or in sluice box riffles, is removed.

In the larger, more organized workings a distinctive herringbone pattern often marks the main drainage system of ground sluice operations. Deep bedrock tunnels and drains are hand-cut to facilitate the discharge of waste water and gravel away from the site. Main drains are intersected by auxiliary branch drains extending out at an angle from the main drains. Mining begins near the base of these drains and moves progressively toward the water source or ditch at the far end of the area to be mined. Pick marks are often observed on their walls. Discrete drainage system subareas are detected within the larger complex of ground sluice diggings. These subareas were usually mined as separate entities and each was fed and drained by a separate network of ditches and drains. Drainage system subareas are often isolated by substantial ridges or areas of unmined deposit. Remnants of unwashed deposits, interspersed between ground sluice workings, serve as drainage divides and substrate to support ditches and flumes (Figures 11-12).

#### Hydraulic Mining

Hydraulic mining was developed directly from the ground sluicing method. The overlapping transitional technologies between ground sluicing and low and high pressure hydraulic mining make it

especially problematic for archaeological interpretation and the terms ground sluicing and hydraulicking have been broadly applied to many aspects of washing gravels. In the strictest sense, an operation is truly considered to be ground sluicing only when the gravels are washed by unpressurized water within a trench cut into the ground. Hydraulic mining uses a stream of water directed under pressure against a bank. In hydraulic mining, water is conveyed to a working face by a pipeline or hose and is forcefully directed against that face through a movable nozzle or monitor. The loosened debris is washed into a waiting system of sluices from which the gold is recovered (Figures 13-14).

For its time, there was no human invention that did more to alter the Sierra landscape than the monitor. Invented in 1852, monitors washed millions of dollars of gold from higher elevations before they were finally turned off in 1884 by a series of U.S. Circuit Court injunctions that prohibited dumping mining debris in rivers that emptied into the Sacramento Valley. Features associated with hydraulic mining bear some resemblance to those of ground sluicing but are usually on a larger scale.

#### Arrastra

Gold that is firmly bound into a placer deposit must first be blasted loose, as evidenced by discarded black powder cans. The consolidated deposit is then crushed with an arrastra, stamp mill, or other crushing device. The arrastra is a primitive gold recovery mill, introduced by early-day Mexican miners, with origins dating back to the stone grain-threshing floors of the ancient world.

A low retaining wall of closely-fitted stone is built in a circle to contain the gravel slurry and keep it in the path of the dragstone. The gold amalgam and excess mercury settles to the bottom of the basin and is collected in the crevices of the rock floor (Figures 15-16).

#### Dredging

Bucket-Line Dredging. Dredges represent the end of a long chain of placer technological developments. Bucket-line dredges operated in California from just before the turn of the century until the mid-1960s; a single operation continues today. Everything is combined into the equivalent of a large, floating factory capable of digging many

cubic feet of material with each bite, then processing it through a revolving screen, and washing the fine materials over riffled sluices where the gold is captured. After washing, the sands are discharged into the pond near the stern of the dredge. Finally, the oversize material from the screen is elevated by a belt-type stacker and deposited on top of the washed sands, leaving high, arc-shaped rock piles behind (Figures 17-20).

Dragline Dredging. As an industry, dragline dredging spanned the period 1932 to 1942. Dragline dredges process a much smaller volume than the bucket-line dredge and are designed to work deposits too small to amortize the capital investment of a bucket-line dredge. A dragline dredge, or "doodlebug," consists of two units. A self-propelled power shovel (dragline), standing on dry land, excavates with a single bucket. The dragline feeds a floating washing plant. Tailings are deposited behind the washing plant (Figures 21-24). Dragline dredge tailings usually take on a configuration of discrete, conical-shaped mounds.

Dry-Land Dredging. Unlike bucket-line and dragline dredges, which float in their own pond of water, dry-land dredges travel on land. During the 1930s a number of so-called "dry-land" dredges were built in California. Most were used for short periods on small tracts of shallow gravel. Typically they consist of a wheel or skid-mounted screening and washing plant which is fed by a power shovel equipped with a dragline boom and bucket (Figure 25). Dry-land dredge tailings are somewhat more irregular in form than either bucket-line or dragline dredge tailings.

#### Mine Prospect Pits

Exploratory diggings were undertaken to test the productive potential of areas thought to contain gold-bearing deposits and were prerequisite to any commitment of capital and labor prior to mining. Remnant hand-dug mine prospect pits vary in diameter and are typically infilled by natural erosion.

## **RECORDATION**

#### Defining the Area

Ascribing artifact, feature, site, or district status

to a set of placer diggings under study can be a large problem. Placer mines can span hundreds, if not thousands, of acres and often comprise overlapping spatial and temporal features. As a result, the complex and multi-layered veneer of mounds, pits and trenches are difficult to sort out. Given these and other problems, a tiered focus is useful in defining the area for recordation by considering first, the historical realities of the placer mine, if known. If not, micro-geologic/topographic/hydrologic boundaries are helpful points of division. On the larger scale, modern geological-mining district boundaries can be used.

### Mapping

Once the area of consideration is established, there is the issue of what to record and to what level of effort. An accurate interpretation of placer mining sites requires not only a thorough job of archival, archaeological and oral history research, but also an appreciation of the nature of gold deposition and an understanding of the mechanics of gold recovery. In this regard, the involvement of a qualified mining engineer/geologist/historian is key. Information in existing archaeological literature may contain errors and it is important to consult with someone with placer mining expertise. Aerial photos are essential to structure both the field survey logistics and feature/site/district mapping. With aerials and expanded scale topographic maps as a base, important mining features can be accurately plotted.

A suite of archaeological features is associated with placer mining landscapes. However, it is not necessary to map every aspect of the mining landscape; rather it is important to identify and categorize the suite of archaeological feature types that reflect the organization of the placer mining process and the evolution of the mine and map the primary water conveyance features and gold recovery works and the assortment of tailings debris. Such a list might include:

- I. Water conveyance features
  - a. Drainage system subareas
  - b. Water supply ditches
  - c. Bedrock drain channels
  - d. Bedrock drain tunnels

- e. Narrow rock-lined channels
  - f. Dredge settling ponds
  - g. Water delivery flumes
  - h. Iron pipe
2. Gold recovery works
    - a. Adits/shafts/tunnels
    - b. Rock retaining walls
    - c. Narrow rock-lined channels
    - d. Ground sluices
    - e. Wooden flume fragments
    - f. Flume or sluice "clean-out" piles
    - g. Unmined deposits
  3. Tailing debris
    - a. Herringbone tailings
    - b. Unorganized tailings
    - c. Pit and mound tailings
    - d. Sluice cut banks, faces or scarps
    - e. Dredge tailings

### Dating

In the absence of diagnostic artifacts, it is the mining landscape that is most useful in understanding the context and character of human activities. Environmental dating techniques, such as dendrochronology, lichenometry and revegetation studies, combine with archival references and diagnostic artifact types, as independent and collaborative evidence with which to roughly place mining features in time.

**Dendrochronology.** Increment borings of a sample of trees growing upon placer tailings and on the cutbanks of mining escarpments, to obtain their ages by ring counts, provide a rough date marking when the ground surface was last disturbed. Although it is impossible to predict the amount of time elapsed since a seed germinated and successfully established itself, the actual age of the tree can provide a minimum date as to when the mining surface was last disturbed.

**Lichenometry.** Mining activities have repositioned ancient buried stream gravels, exposing previously uncolonized boulder surfaces to favorable orientations for lichen colonization. Measurement of the diameters of the largest colonies of lichen is sufficient to indicate the lichen's age relative to another colony similarly measured for the same species. The relative growth of the long-lived crustose lichen,

*Rhizocarpon*, present on tailings features throughout the Mother Lode region, is measured against lichen growing on dated tombstones in nearby cemeteries or dated structures, which are used as a control.

**Post-Abandonment Revegetation.** Upon cessation of mining activities, vegetation communities begin to recolonize the disturbed soil. A tentative time curve representing the rate of this revegetation process on historic placer mining tailings in the region is developed by comparing the amount of vegetation on other local placer mining sites of a known age and occurring within the same temperature and moisture regime. Vegetation features of interest are the average diameters and stand uniformity of trees, the density and maturity of shrubs, the percent cover of grasses and forbs, and the relative ground surface stability of mining cut banks and infilling of mine prospects.

**Metal Detection.** Odds for encountering diagnostic artifacts and defining activity areas are greatly increased with the use of systematic metal detection. A number of local metal detection clubs enthusiastically offer their expertise in this effort.

**Interpretation.** Beyond archaeological research interests is the need to interpret historic mining events and features. One means of reaching the public is through the production of popular history vignettes and videos that integrate archival and archaeological information, oral histories, photos, and maps of the more interesting aspects of a mining site (Lindström, Wilson and Szumski 1994; Wilson, Blanchard and Lindström 1994).

## CONCLUSION

Just as we are realizing the research potential of landscape features to reflect the organization and evolution of the placer mining process and just as we are recognizing the interpretive power of their visual signature, they are vanishing. Because of their imposing presence, their large scale, their relative permanence, and their importance as accurate indicators of time-specific technological processes, Richard Francaviglia (1988) has characterized mining-related

topography as the "ultimate artifact." No longer can the mining landscape be overlooked as background or dispensed with in the single word -- "tailings."

## REFERENCES CITED

- Francaviglia, Richard  
1988 The Ultimate Artifact: Interpreting and Evaluating the Man-Made Topography of Historic Mining Districts. Paper presented at the Annual Meeting of the Society for Historical Archaeology. Reno.
- Lindström, Susan  
1997 Heritage Resource Inventory, Valley View Specific Plan EIR, 2038-Acre Parcel near El Dorado Hills, California, El Dorado County. Prepared for Wagstaff and Associates, Berkeley, California. Report on file North Central Information Center, California State University, Sacramento.
- Lindström, Susan G. and John Wells  
1989 A Cultural Resource Evaluation of the Aerojet Project, 8500 acres near Folsom, California, Sacramento County. Prepared for Aerojet General Corporation, Sacramento. Report on file North Central Information Center, California State University, Sacramento.  
1990 A Historic Sites Archaeological Survey of the Main Hydraulic Pit Basin, Malakoff Diggins State Historic Park, North Bloomfield, Nevada County. Prepared for State of California Department of Parks and Recreation, Sacramento, California. Report on file North Central Information Center, California State University, Sacramento.
- Lindström, Susan, John Wells, and Norman Wilson  
1988a A Comparative Evaluation of the Natoma Ground Sluice Diggings, Folsom, California, Sacramento County. Prepared for EIP Associates, Sacramento. Report on file North Central Information Center, California State University, Sacramento.  
1988b A Cultural Resource Evaluation of the Los Cerros-Morrison Homes Project, 140 acres near Folsom, Sacramento County. Report on file North Central Information Center, California State University, Sacramento.  
1993a A Cultural Resource Inventory of Prairie City Center Project, 404 acres near Folsom, California, Sacramento County. Prepared for Western Savings and Loan Corporation, Marina del Rey, California. Report on file North Central Information Center, California State University, Sacramento.

1993b A Cultural Resource Inventory of Prairie Oaks Center Project, 90 Acres near Folsom, California, Sacramento County. Prepared for the City of Folsom. Report on file North Central Information Center, California State University, Sacramento.

Lindström, Susan, Norman Wilson and Richard Szumski  
1994 *Spanish Hill: Placerville's Mountain of Gold* (video production, copyright 1994 by Susan Lindström, Norman Wilson and Richard Szumski, Truckee, California).

Lindström, Susan, Norman Wilson, Dana Supernowicz, George Wheeldon, and John Wells

1994 A Cultural Resource Evaluation of the Spanish Hill Diggings Weatherstone Village EIR, a 70-Acre Planned Development near Placerville, California, El Dorado County. Report prepared for the City of Placerville. Report on file North Central Information Center, California State University, Sacramento.

Wilson, Norman, Charles Blanchard and Susan Lindström

1994 *Spanish Hill: Placerville's Mountain of Gold*. Wilson, Blanchard and Lindström, Truckee, CA.

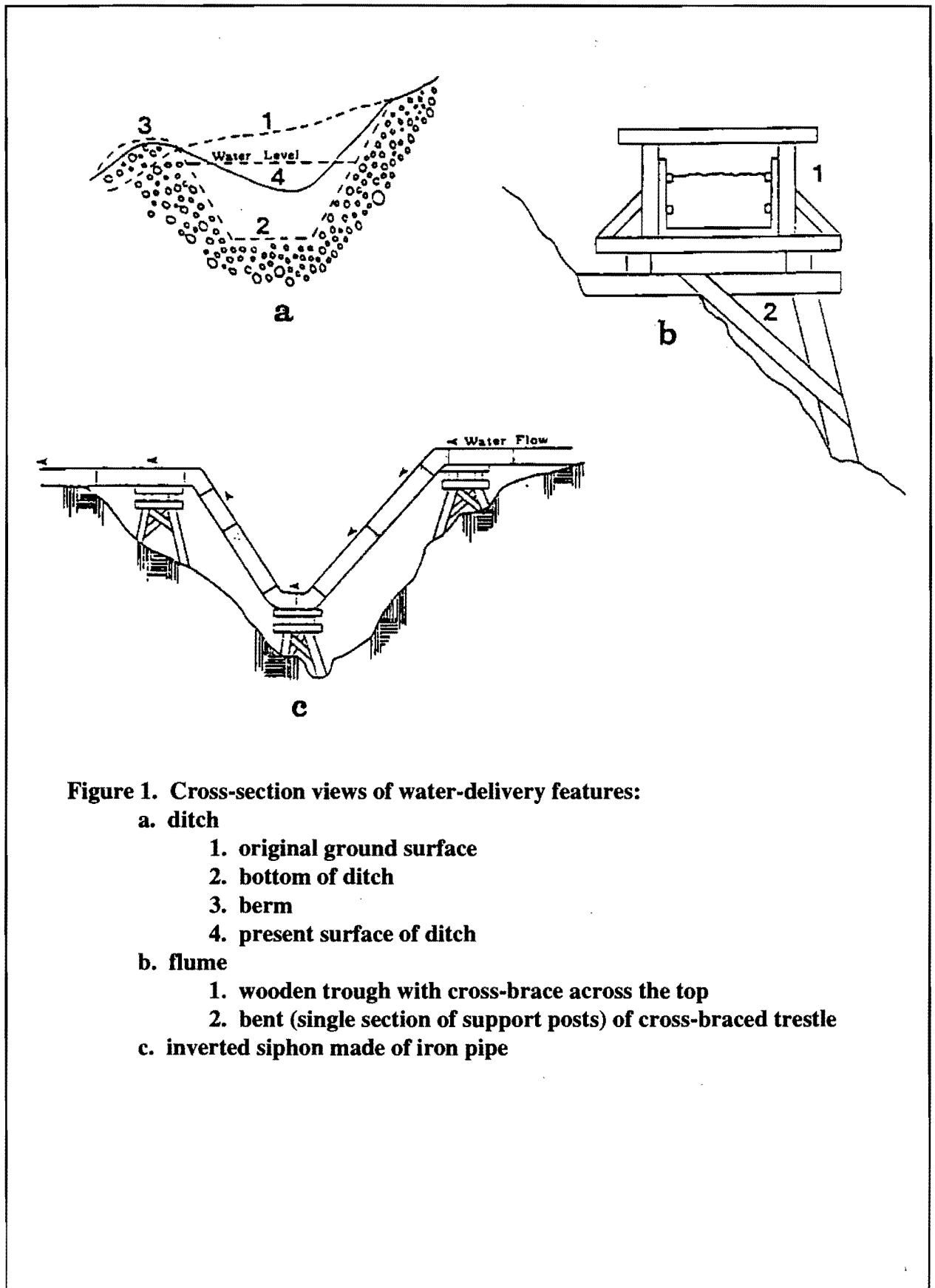

**Figure 1. Cross-section views of water-delivery features:**

**a. ditch**

- 1. original ground surface**
- 2. bottom of ditch**
- 3. berm**
- 4. present surface of ditch**

**b. flume**

- 1. wooden trough with cross-brace across the top**
- 2. bent (single section of support posts) of cross-braced trestle**

**c. inverted siphon made of iron pipe**

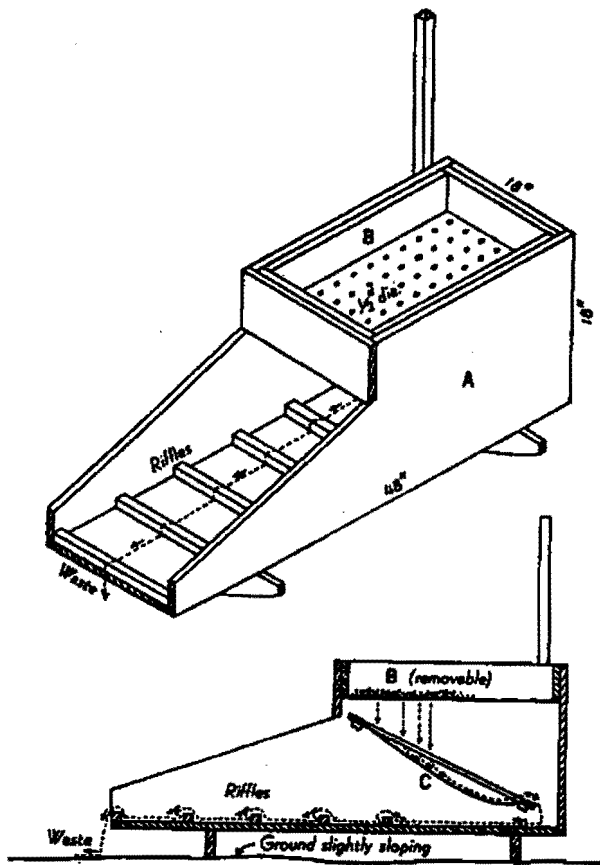

**Figure 2. Rocker. Dirt and water are put into "B" and the apparatus is rocked by handle. Water and sand and gold pass through holes onto apron "C" where most of the black sand and gold are caught, then over riffles by which more gold is caught, and finally to waste. Material remaining in "B" is thrown out and the apron is removed and washed.**



Figure 3. Rocker

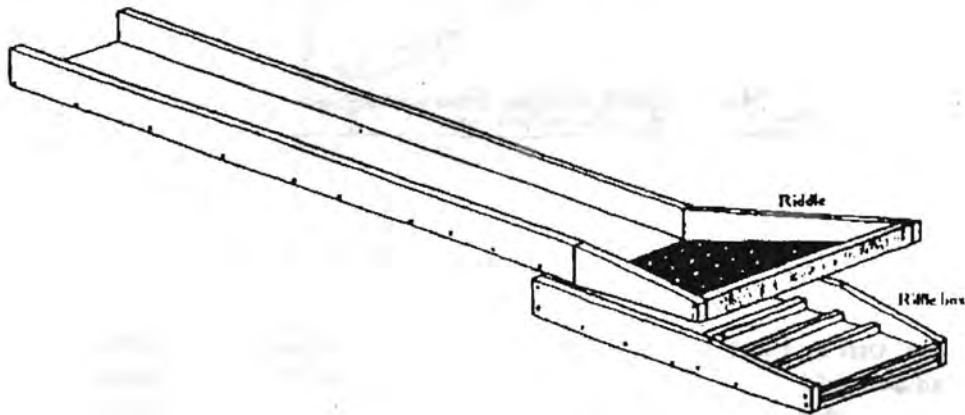

Figure 4. Long tom. The long tom consists of an inclined wooden trough with a perforated iron plate (riddle) across its lower end, and below this, a separate riffle box. While two or more men shovel into the tom, another stirs the material and forks out the washed rocks. After passing through perforations in the riddle, the minus-half-inch fines flow across the riffle box where the gold is caught. Water is delivered to the tom by a ditch or canvas hose.



Figure 5. Long Tom



Figure 6. Sluice Box

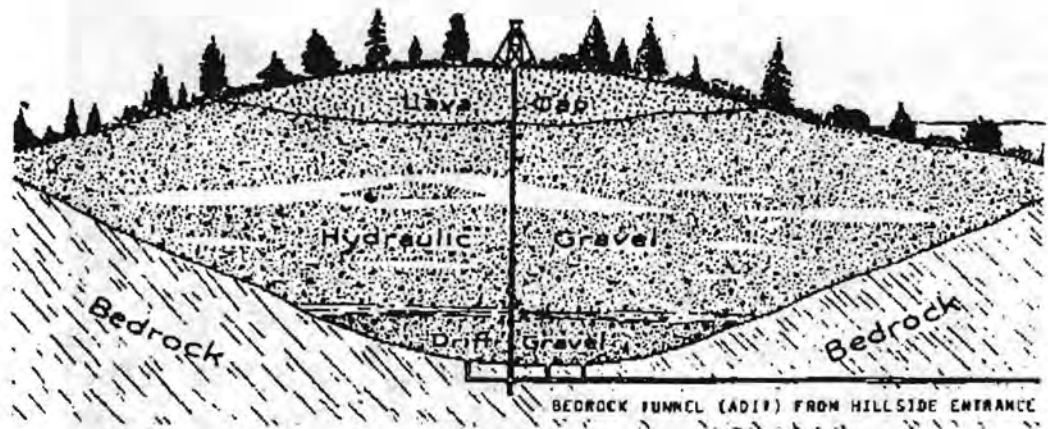

Figure 7. Ideal cross-section through a Tertiary gravel channel showing bottom (drift mine) gravel, overlain by lava-capped gravel suitable for hydraulic mining.

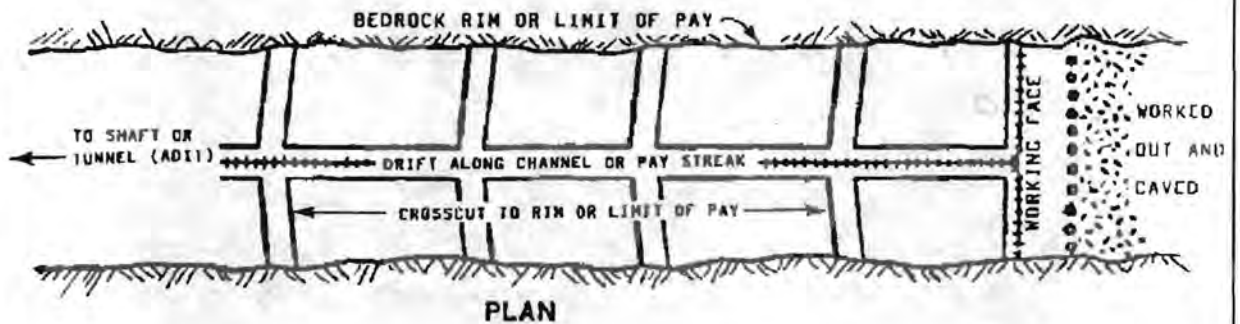

Figure 8. Plan view of drift mine workings in a narrow pay channel. Mining (breasting) is proceeding from right to left toward an access shaft or a bedrock tunnel (adit) which served as a drain and haulageway.



**Figure 9. Chinese miners ca. 1900. Drift mines are worked through vertical shafts sunk to bedrock. From the bottom of the shaft, drifts are run along the bedrock and the pay gravel is brought to the surface by a windlass where it is washed in rockers or sluices.**



**Figure 10. Drift mining works placer deposits by underground methods.**

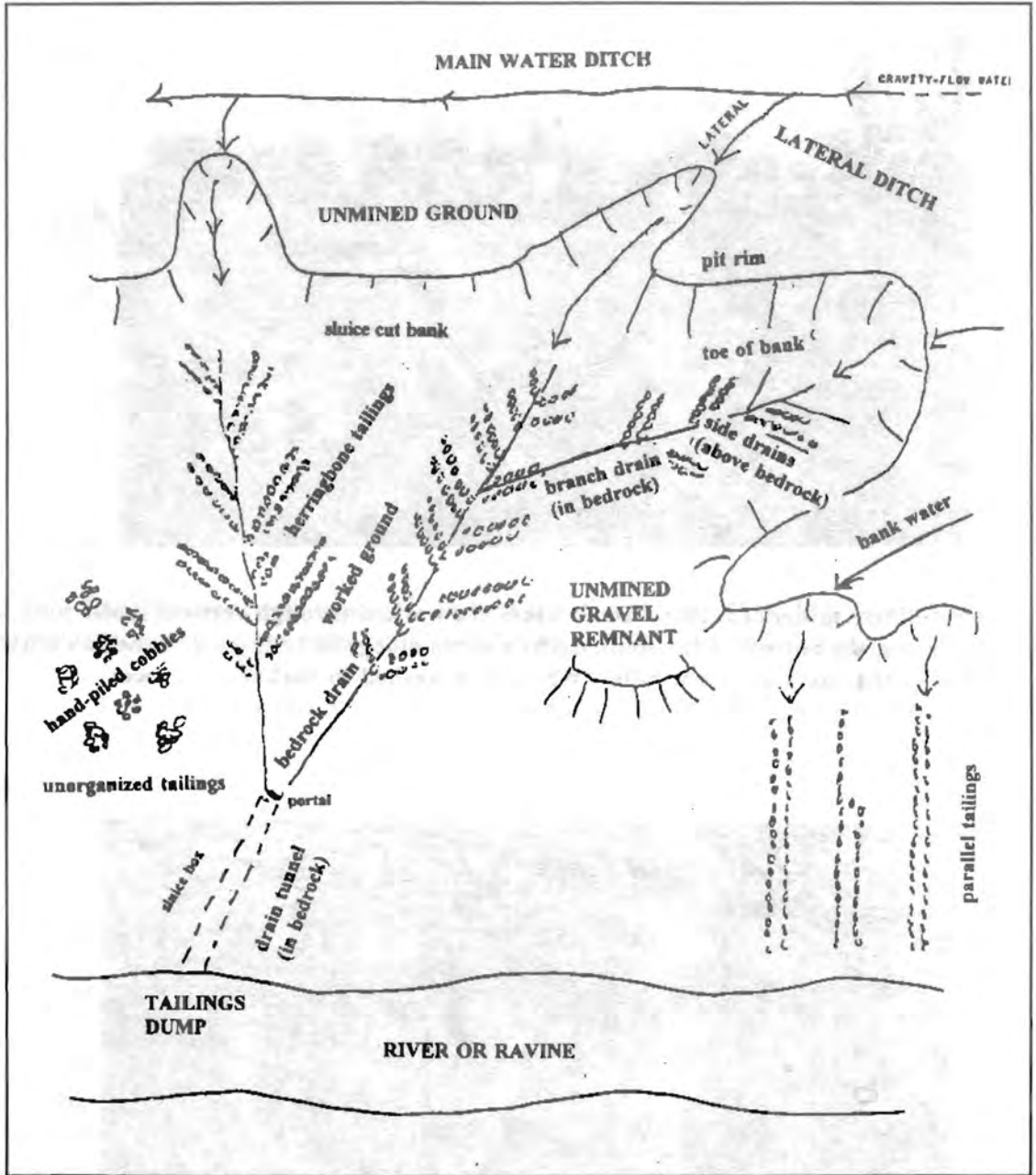
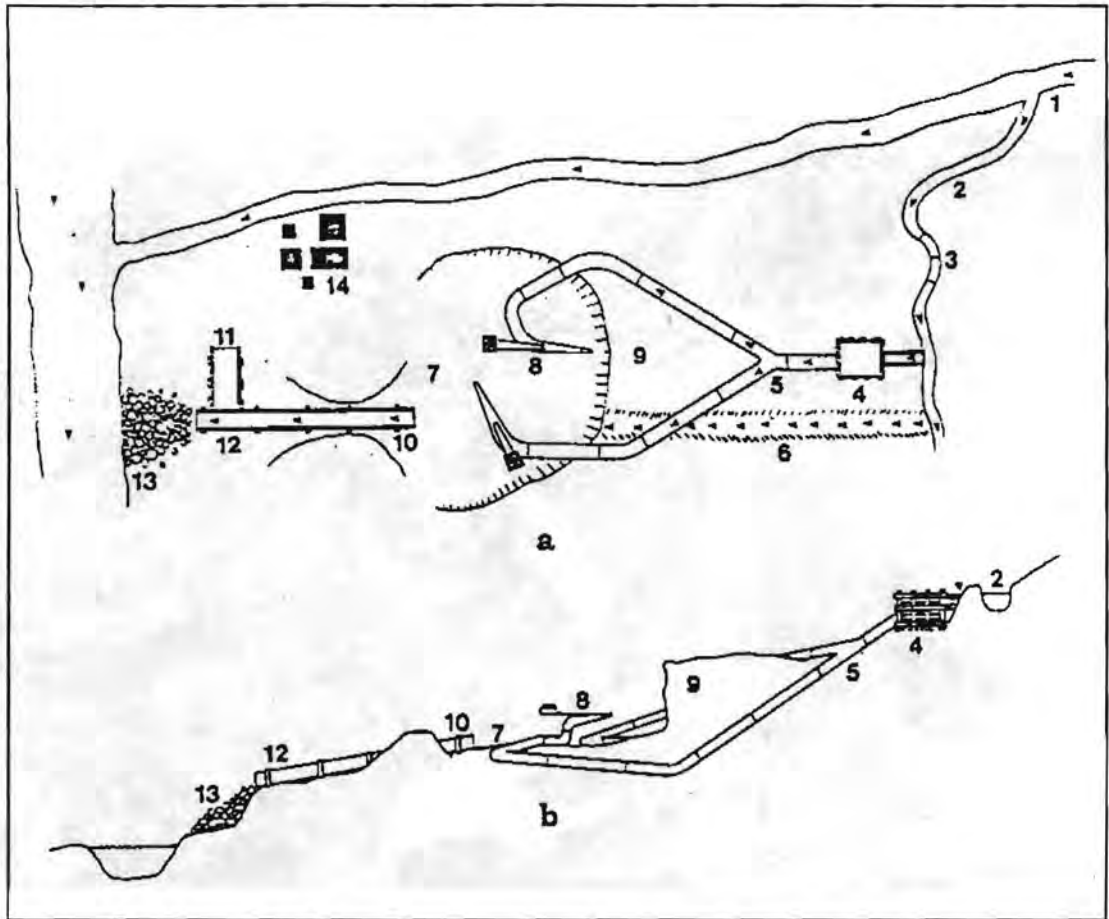

Figure 11. Schematic diagram of ground sluice workings.



**Figure 12. Ground sluicing in El Dorado County**



**Figure 13. Schematic representation of typical hydraulic mining operation:**

**a. plan-view**

1. ditch intake
2. lateral ditch
3. flume across steep draw
4. headbox
5. penstock in inclined ditch
6. sluice water channel
7. floor of washing pit
8. feeder pipe and nozzle (penstocks often divided into two or more feeder pipes by means of "Y" -junctions)
9. headwall of washing pit
10. sluice boxes
11. undercurrent sluice
12. tailings sluice
13. tailings pile
14. camp (including supply sheds and shops)

**b. cross section**

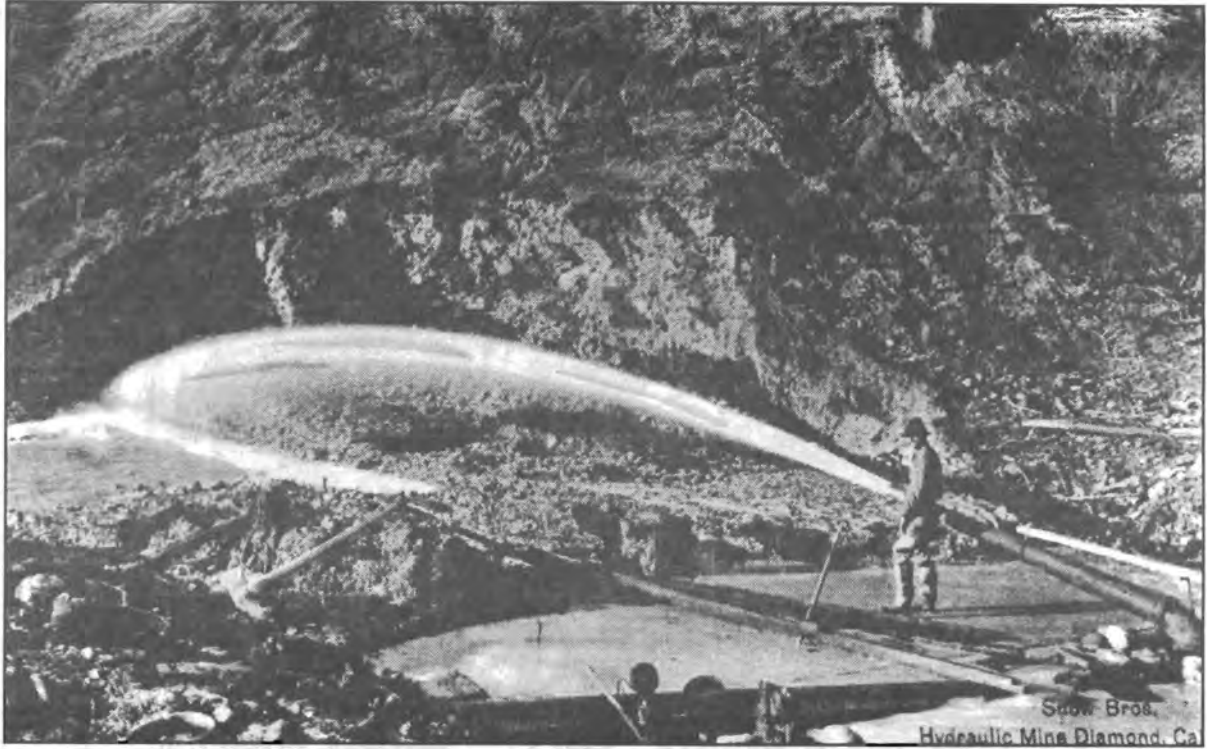

Figure 14. Snow Brothers Mine - a typical hydraulic mining scene in El Dorado County.

Figure 15. Small arrastra with two dragstones.

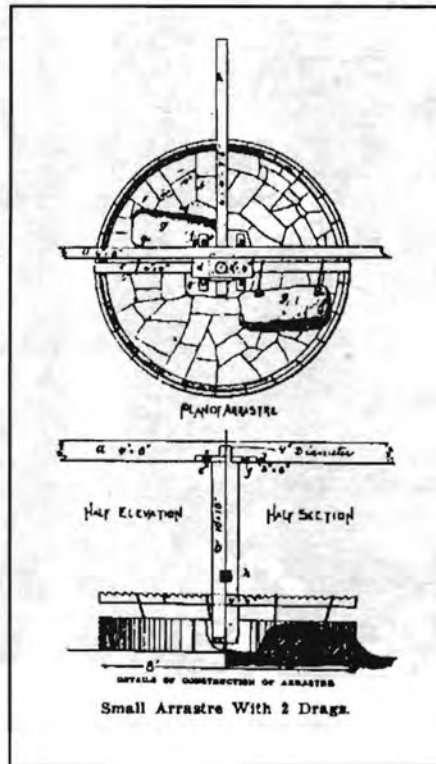
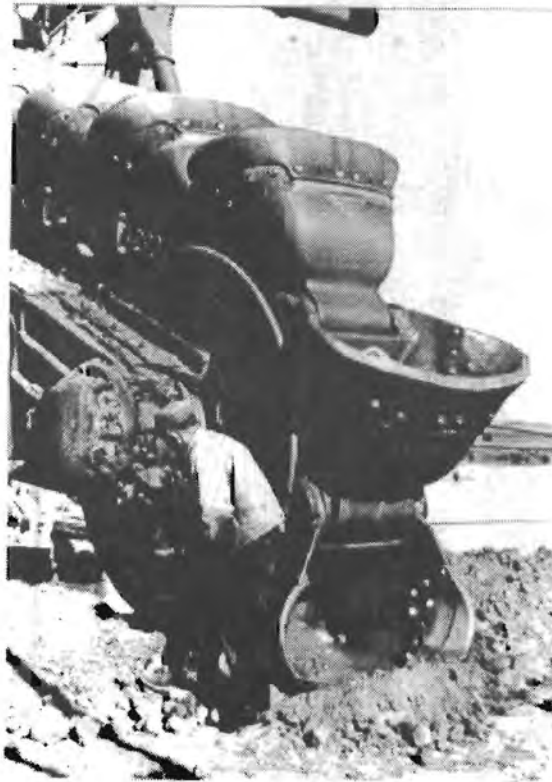



Figure 16. Arrastra



**Figure 17. Bucket-line dredge, Natoma No. 6 working approximately one mile south of White Rock Road and ½ mile east of Sunrise Boulevard, Folsom, September 7, 1959.**



**Figure 18. Bucket-line dredge, 17-cubic-foot buckets, Natoma No. 1, November 28, 1957.**

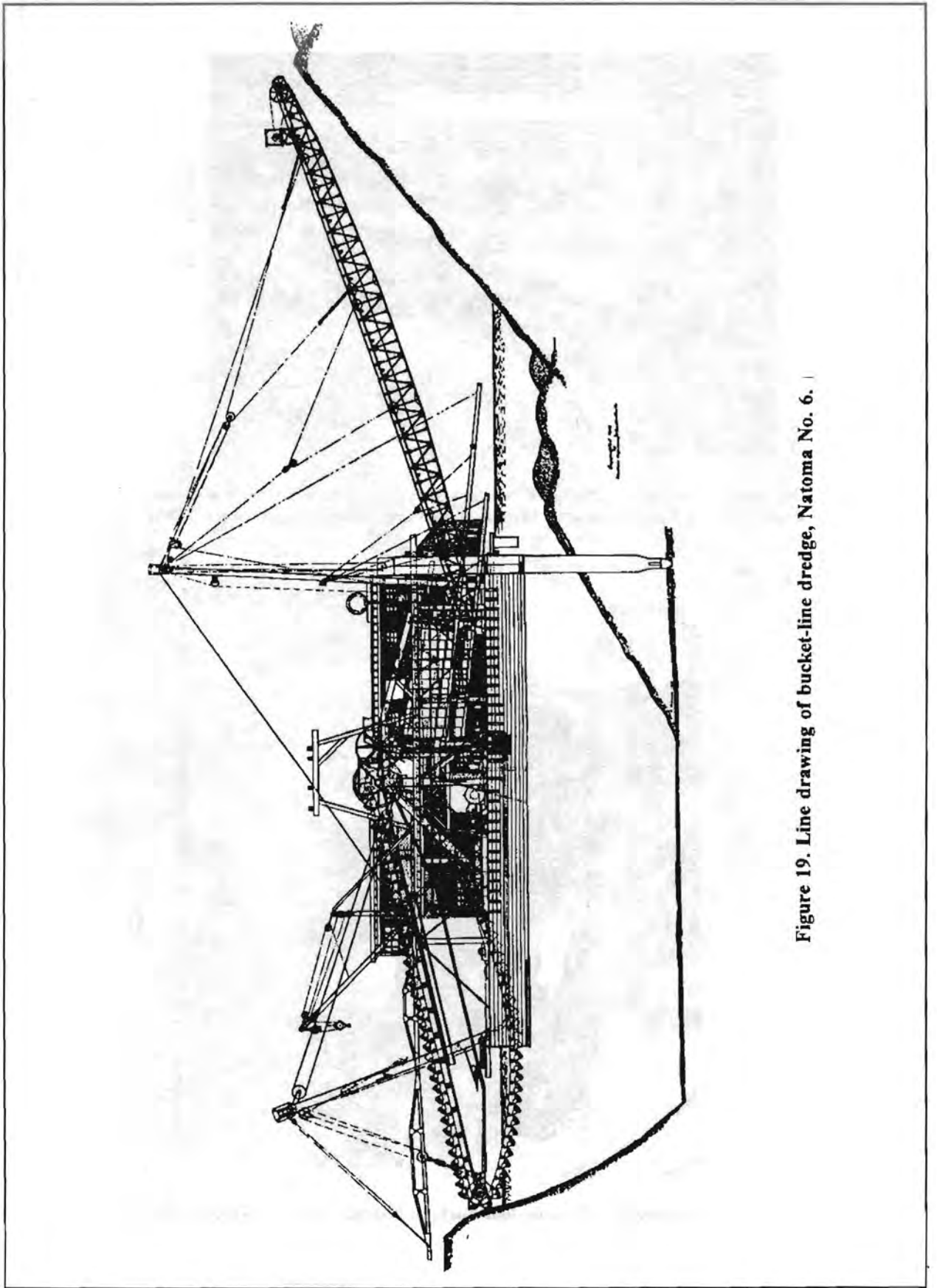

Figure 19. Line drawing of bucket-line dredge, Natoma No. 6. |

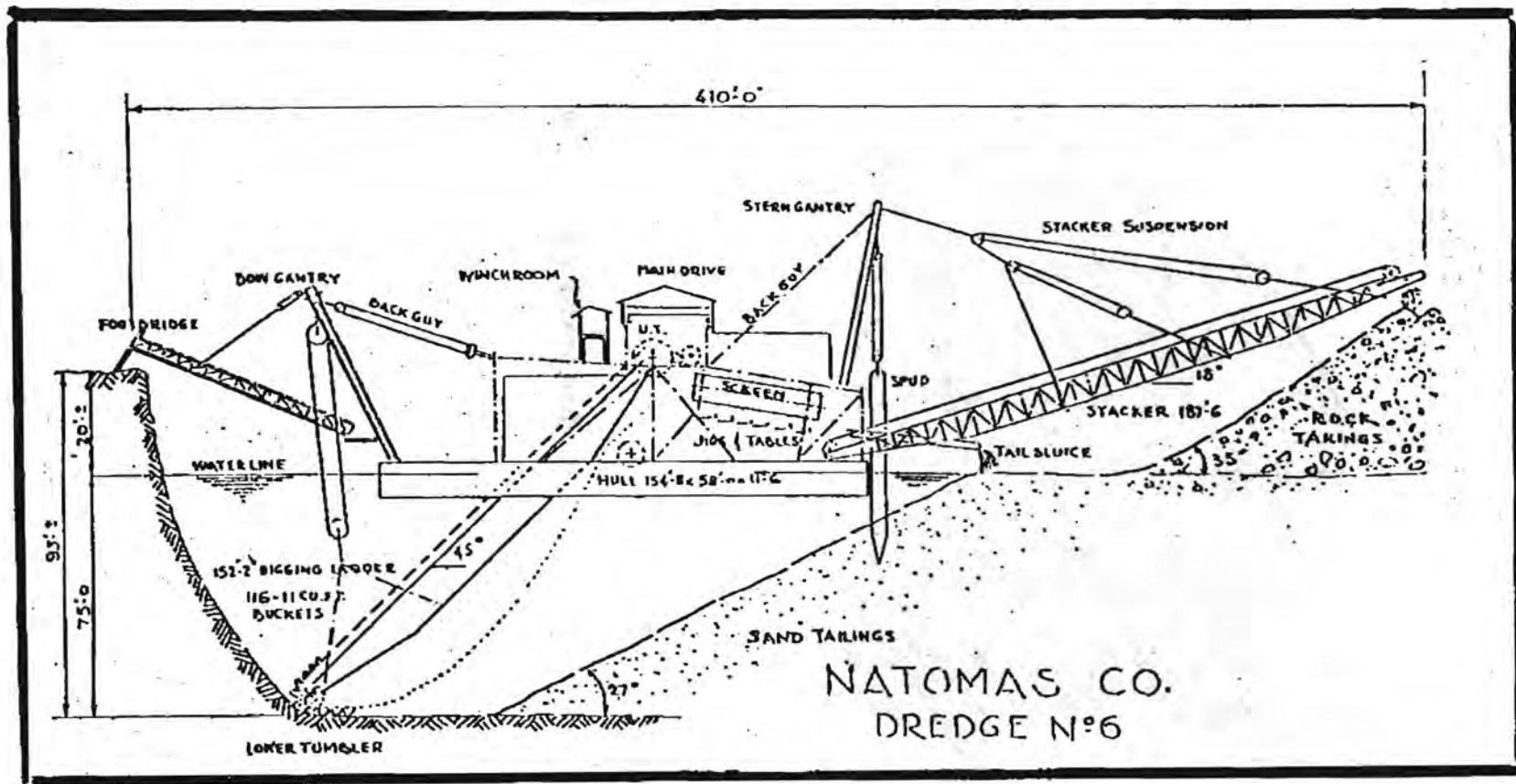

Figure 20. General arrangement of a modern bucket-line gold dredge.

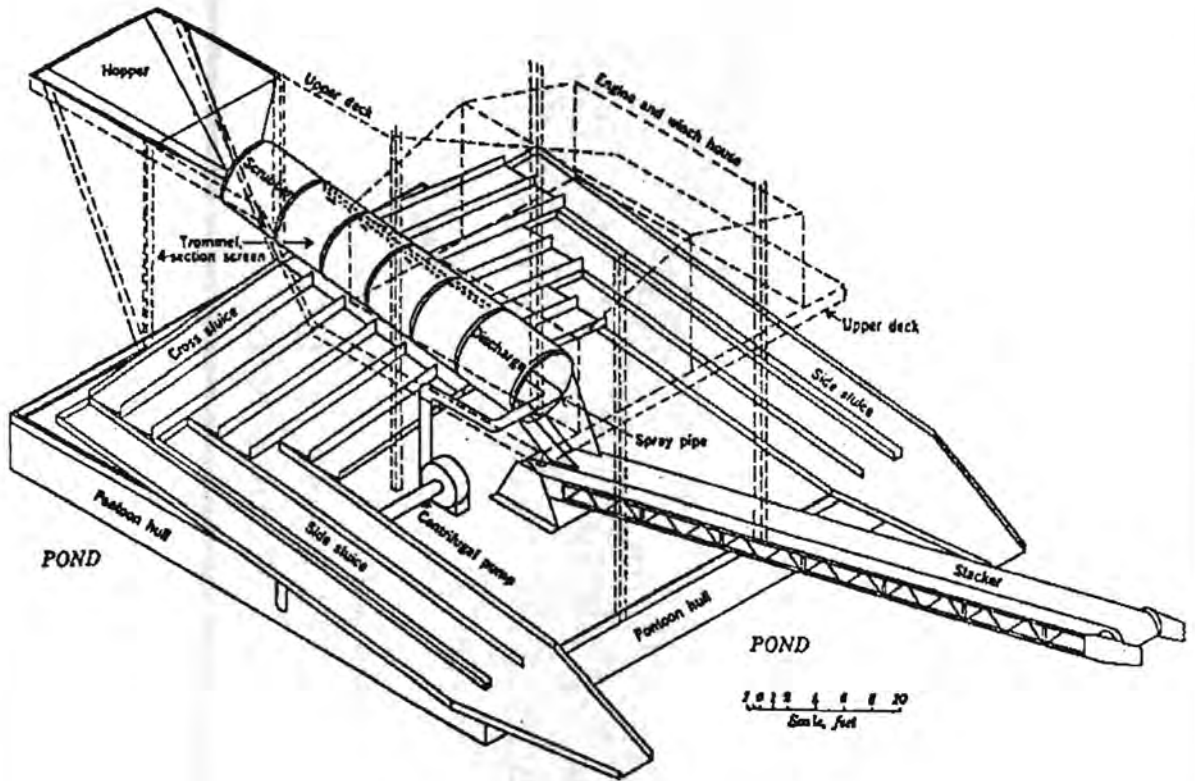

Figure 21. Essential features of a dragline dredge washing plant.

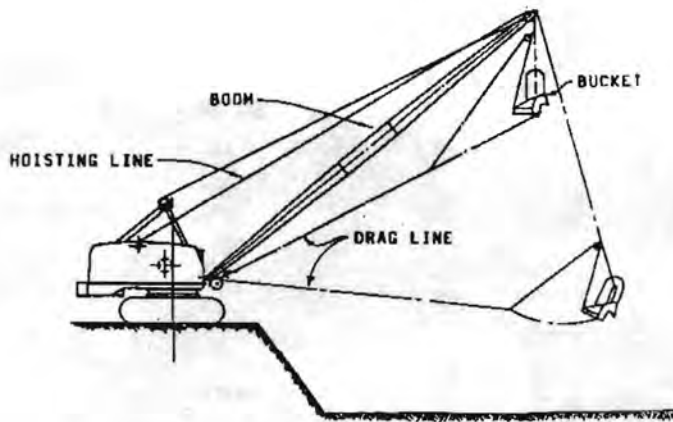

Figure 22. Dragline excavator used to dig and feed gold-bearing gravel to a dragline dredge.

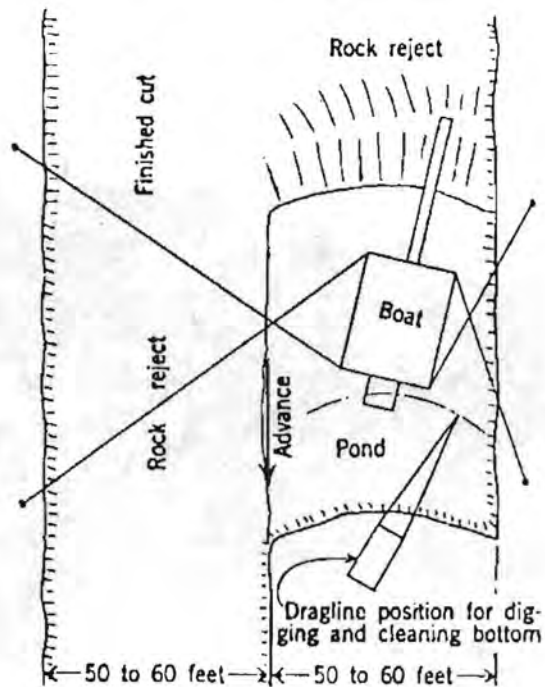

Figure 23. Typical set-up for mining with a dragline dredge.

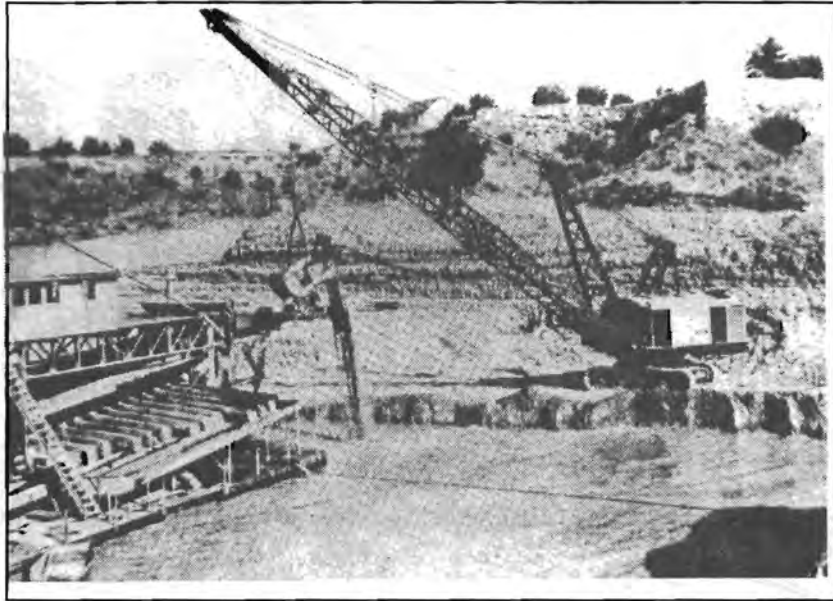

Figure 24. Dragline dredge.



Figure 25. Dry-land dredge.

## FIGURE CREDITS

Figure 1. Jeffrey LaLande. Sojourners in Search of Gold: Hydraulic Mining Techniques of the Chinese on the Oregon Frontier. *The Journal of the Society for Industrial Archaeology* 11(1):29- 52 (page 33). 1985.

Figure 2. (drawn by) John Wells. El Dorado Hills, California.

Figure 3. Arizona Bureau of Mines. Gold Placers and Placering in Arizona: Rocker in Operation, Copper Basin District. *Bulletin 168* (Plate XI). 1961.

Figure 4. (drawn by) John Wells. El Dorado Hills, California.

Figure 5. Daguerreotype from the collection of the California State Division of Mines (now on permanent loan in the California State Library, Sacramento). California Section, California State Library, Sacramento.

Figure 6. Daguerreotype from the collection of the California State Division of Mines (now on permanent loan in the California State Library, Sacramento). California Section, California State Library, Sacramento.

Figure 7. (drawn by) John Wells, El Dorado Hills, California.

Figure 8. (drawn by) John Wells, El Dorado Hills, California.

Figure 9. State of California, Department of Parks and Recreation. Sacramento.

Figure 10. Murray Morgan. *One Man's Gold Rush: A Klondike Album*. Seattle: University of Washington Press (page 151). 1967.

Figure 11. (drawn by) John Wells, El Dorado Hills, California.

Figure 12. El Dorado County Historical Museum. Placerville, California.

Figure 13. Jeffrey LaLande. Sojourners in Search of Gold: Hydraulic Mining Techniques of the Chinese on the Oregon Frontier. *The Journal of the Society for Industrial Archaeology* 11(1):29- 52 (page 38). 1985.

Figure 14. El Dorado County Historical Museum. Placerville, California.

Figure 15. State of California, Report of the State Mineralogist *Report 30*. 1934:268.

Figure 16. Owen C. Coy. *A Pictorial History of California* University of California Extension Division, Berkeley, and Wells Fargo Bank and Union Trust Company, San Francisco (reprint of original etching).

Figure 17. John Wells, El Dorado Hills, California.

Figure 18. John Wells, El Dorado Hills, California.

Figure 19. "Line Drawing of Natoma No. 6 (1915-1916)," in possession of John Wells, El Dorado Hills, California.

Figure 20. (drawn by) E.A. Foster, Natomas Company (company information sheet), ca. 1955.

Figure 21. U.S. Bureau of Mines 1.c.7013.

Figure 22. John Wells, El Dorado Hills, California.

Figure 23. John Wells, El Dorado Hills, California.

Figure 24. John Wells, El Dorado Hills, California.

Figure 25. John Wells, El Dorado Hills, California.